

FINEST QUALITY

Union Special[®]
LEWIS • COLUMBIA

**INDUSTRIAL
SEWING
MACHINES**

**CLASS
51300**

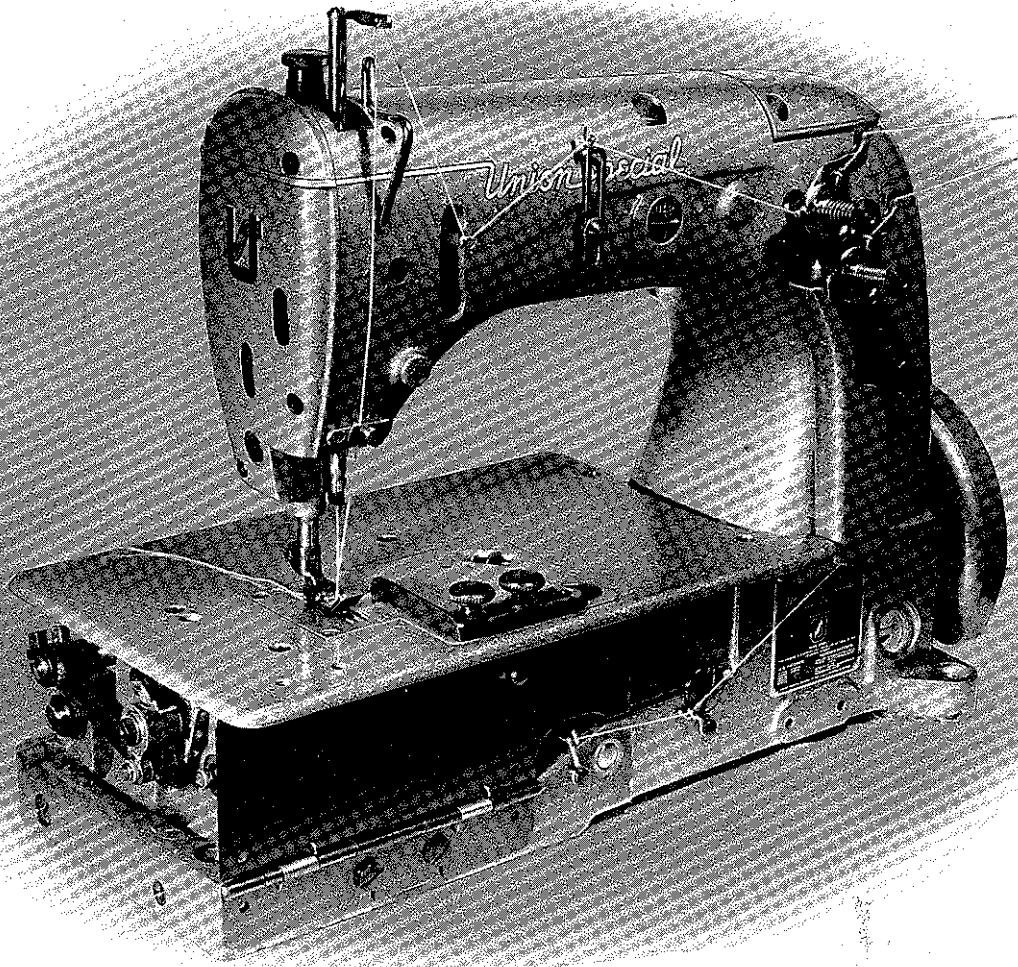

**CATALOG
No.
104V**

**LIST OF PARTS
FOR
STYLE 51300BV**

Union Special CORPORATION

CHICAGO

Here are Oil Specifications for Union Special Sewing Machines

Specification 174 specifies a high quality petroleum oil, viscosity 100 seconds at 100°F. Recommended for all oiling applications on high speed machines.

Specification 175 specifies a high quality petroleum oil, viscosity 100 seconds at 100°F., water white or with a maximum A.S.T.M. color number of 1. *For use where freedom from oil staining is paramount.*

Specification 87 specifies a high quality petroleum oil, viscosity 300 seconds at 100°F.

Specification 100 specifies a general purpose high quality grease for use in ball bearings and transmitters. It is similar to commercial N.L.G.I., grease No. 3. Where No. 3 grease is not obtainable, No. 2 may be used.

UNION SPECIAL

SPECIFICATION NO.	174	175	87
Viscosity S.S.U. at 100°F	90-125	90-125	300-350
Flash (Min.)	350	350	350
Pour (Max.)	20	20	20
Color A.S.T.M. (Max.)	3	1	3
Neutralization No. (Max.)	0.10	0.10	0.10
Viscosity Index			
(D & D Min.)	85	85	85
Compounding	None	None	None
Copper Corrosion (Max.)	1A	1A	1A

*Anline No. 175-225 175-225 175-225

*Used with Buna N Rubber "O" Retainers



NOTE 1: The use of non-corrosive additives in oils meeting above classification is desirable but not essential. These may include:

1. Oxidation inhibitors
2. Rust inhibitors
3. Lubricity additives
4. Anti-oxidants
5. Film strength additives

These additives must be completely soluble in the oil and not removable by wick feeding nor shall they separate.

NOTE 2: Oils containing the following type additives shall not be used at any time:

1. Extreme pressure additives—corrosive
2. Tackiness or adhesive additives
3. Lead soap additives
4. Detergents

 **Union Special**[®]
FINEST QUALITY
CORPORATION

Catalog No. 104 V
(Supplement to Catalog No. 104 L)

LIST OF PARTS

CLASS 51300

Style

51300 BV

First Edition

Copyright 1961
by
Union Special Corporation
Rights Reserved in All Countries

Union Special
CORPORATION
INDUSTRIAL SEWING MACHINES
CHICAGO

Printed in U. S. A.

September, 1973

IDENTIFICATION OF MACHINES

Each Union Special machine is identified by a Style number which is stamped into the name plate on the machine. Style numbers are classified as standard and special. Standard Style numbers have one or more letters suffixed, but never contain the letter "Z". Example: "Style 51300 BV". Special Style numbers contain the letter "Z". When only minor changes are made in a standard machine, a "Z" is suffixed to the standard Style number. Example: "Style 51300 BVZ".

Styles of machines similar in construction are grouped under a class number which differs from the style number, in that it contains no letters. Example: "51300".

APPLICATION OF CATALOG

This catalog is a supplement to Catalog No. 104 L, and should be used in conjunction therewith. Only parts found on Style 51300 BV, but not on Style 51300 BG are illustrated. Opposite the illustrated page, parts are identified by detail number, part number, description and amount required. For clarity, certain 51300 BG parts are shown in phantom to help locate 51300 BV parts.

This catalog applies specifically to the Standard style of machine as listed herein. It can also be applied with discretion to some Special machines in this Class. References to direction, such as right, left, front, back, etc., are given from the operator's position while seated at the machine. Operating direction of handwheel is toward the operator.

STYLE OF MACHINE

Streamlined Flat Bed, Medium Throw, Single Needle, With Back Tacking Mechanism, Light Weight Presser Bar, Light Weight Needle Bar and Needle Bar Driving Mechanism, Needle Bearing Needle Bar Drive, Single Reservoir Enclosed Automatic Lubricating System, Filter Type Oil Return Pump With Base Plate, Oil Siphon Assembly, Lateral Looper Travel, Light Weight Pulley, Prepared for Oil Shields, Work Space to Right of Needle Bar 7 3/4 Inches.

51300 BV For seaming light to medium weight materials where back tacking is required. Seam Specification 401-SSa-1. Stitch range 10 to 16 per inch.

NEEDLES

Each Union Special needle has both a type number and a size number. The type number denotes the kind of shank, point, length, groove, finish and other details. The size number, stamped on the needle shank, denotes the largest diameter of blade measured in thousandths of an inch, midway between the shank and the eye. Collectively, the type number and the size number is the complete symbol.

Standard needle for Style 51300 BV is Type 130 GHS. It has a round shank, round point, short, double groove, struck groove, ball eye, spotted, government, short blade 1/8 inch less than standard, width of eye and groove undersize, one step reduction, ball point, chromium plated - sizes 032, 036, 040, 044, 049, 054.

To have needle orders promptly and accurately filled, an empty package, a sample needle, or the type and size number should be forwarded. Use description on label. A complete order would read: "1000 Needles, Type 130 GHS, Size 036".

Selection of the proper needle size should be determined by size of thread used. Thread should pass freely through needle eye in order to produce a good stitch formation.

USE GENUINE NEEDLES AND REPAIR PARTS

Success in the operation of these machines can be secured only with genuine Union Special Needles and Repair Parts as furnished by the Union Special Corporation, its subsidiaries and authorized distributors. They are designed according to the most approved scientific principles, and are made with utmost precision. Maximum efficiency and durability are assured.

Genuine needles are packaged with labels marked *Union Special*. Genuine repair parts are stamped with the Union Special trade mark. Each trade mark is your guarantee of the highest quality in materials and workmanship.

IDENTIFYING PARTS

Where construction permits, each part is stamped with its part number. On some of the smaller parts and on those where construction does not permit, an identification letter is stamped in to distinguish the part from similar ones.

Part numbers represent the same part, regardless of catalog in which they appear.

IMPORTANT! ON ALL ORDERS, PLEASE INCLUDE PART NAME AND STYLE OF MACHINE FOR WHICH PART IS ORDERED.

TERMS

Prices are strictly net cash and are subject to change without notice. All shipments are forwarded f. o. b. shipping point. Parcel Post shipments are insured unless otherwise directed. A charge is made to cover postage and insurance.

OILING

The oil has been drained from the machine before shipping, and the reservoir must be filled before beginning to operate. Use a straight mineral oil with a Saybolt viscosity of 90 to 125 seconds at 100° Fahrenheit.

Oil is filled at the spring cap in the top cover and the level is checked at the sight gauge on the front of the machine. The oil level should be maintained between the red lines on the gauge. The capacity of the oil reservoir is 12 ounces.

The machine is automatically lubricated and no oiling, other than keeping the main reservoir filled, is necessary.

A daily check before the morning start should be made and oil added if required. Oil which has gone through the machine is filtered and pumped back into the main reservoir, making too frequent oilings unnecessary. Excessive oil in the main reservoir may be drained at the plug screw in the main frame directly under the handwheel.

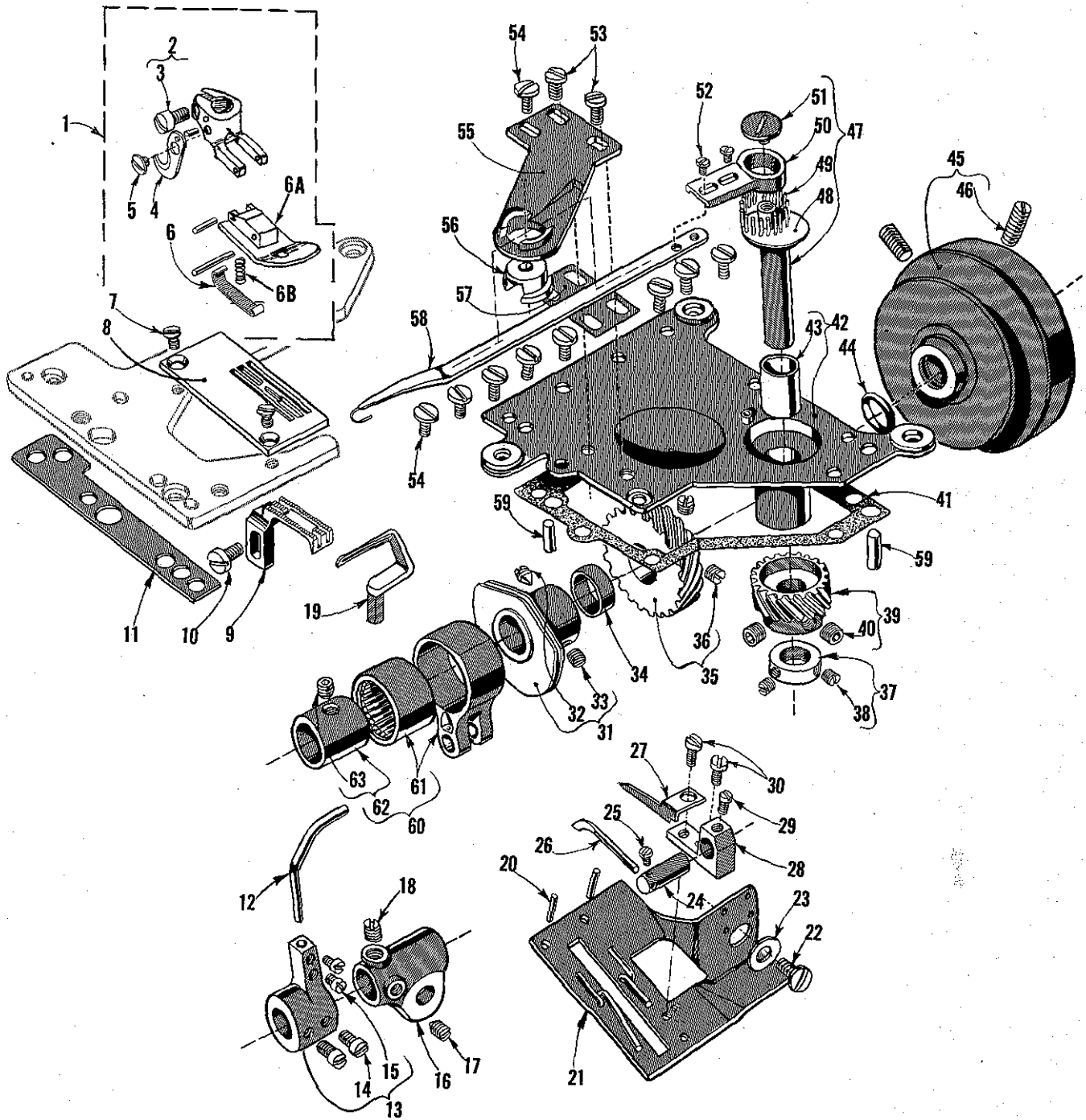

SEWING PARTS COMBINATION, TAKE-UP, CAST-OFF PLATE AND
BACK TACKING MECHANISM

Ref. No.	Part No.	Description	Amt. Req.
1	51320 N	Presser Foot -----	1
2	51330 AK	Presser Foot Shank -----	1
3	91	Screw -----	1
4	1741 B	Chain Cutting Knife -----	1
5	187 B	Screw -----	1
6	51330 AM	Yielding Section -----	1
6A	51330 AL	Presser Foot Bottom -----	1
6B	51330 W	Spring -----	1
7	87	Screw -----	2
8	51324 H	Throat Plate -----	1
9	51305 H	Feed Dog -----	1
10	22528	Screw -----	1
11	51380 B	Throat Plate Support Shim -----	1
12	51325	Looper Needle Guard -----	1
13	52825 D	Looper Needle Guard Holder -----	1
14	33174 B	Screw -----	2
15	22563	Screw -----	2
16	52444 B	Looper Rocker Frame -----	1
17	96	Spot Screw -----	1
18	98	Set Screw -----	1
19	51308	Looper -----	1
20	50-216 Blk.	Dowel Pin -----	2
21	51357 A	Cast-off Support Plate -----	1
22	22528	Screw -----	1
23	21657 E	Washer -----	1
24	51204 A	Retainer Finger Holder -----	1
25	22798 A	Screw -----	1
26	51204	Retainer -----	1
27	51204 B	Cast-off -----	1
28	51204 C	Cast-off Support -----	1
29	77	Screw -----	1
30	J87 J	Screw -----	2
31	51423 C	Take-up -----	1
32	96	Spot Screw -----	1
33	22580 D	Set Screw -----	1
34	51351 H	Drive Gear Spacer -----	1
35	51351	Loop Retainer Drive Gear -----	1
36	98	Screw -----	2
37	39147 D	Collar -----	1
38	88	Screw -----	2
39	51351 A	Loop Retainer Driven Gear -----	1
40	22580 E	Screw -----	2
41	51382 A	Oil Reservoir Top Cover Gasket -----	1
42	51382	Oil Reservoir Top Cover -----	1
43	51351 C	Crank Bushing -----	1
44	660-202	Oil Seal Ring -----	1
45	51221 C	Pulley -----	1
46	22894 F	Screw -----	2
47	29126 DR	Crank Drive Assembly -----	1
48	51351 B	Loop Retainer Driving Crank -----	1
49	61451 D	Needle Bearing Rollers -----	16
50	51351 D	Crank Link -----	1
51	22757 F	Screw -----	1
52	604	Screw -----	2
53	22570 A	Screw -----	2
54	22585 A	Screw -----	9
55	51351 G	Fulcrum Bearing Bracket -----	1
56	51351 F	Fulcrum and Slide Block -----	1
57	51351 J	Shim (as required) -----	1
58	51351 E	Loop Retainer Hook -----	1
59	667 C-8	Dowel Pin -----	2
60	29476 DV	Looper Avoid Eccentric Assembly -----	1
61	51145 A	Eccentric Bearing -----	1
62	51406	Looper Avoid Eccentric, .062 inch throw -----	1
63	22894 D	Screw -----	1
-	53183 A	Lifter Lever Link (not shown on picture plate) -----	1

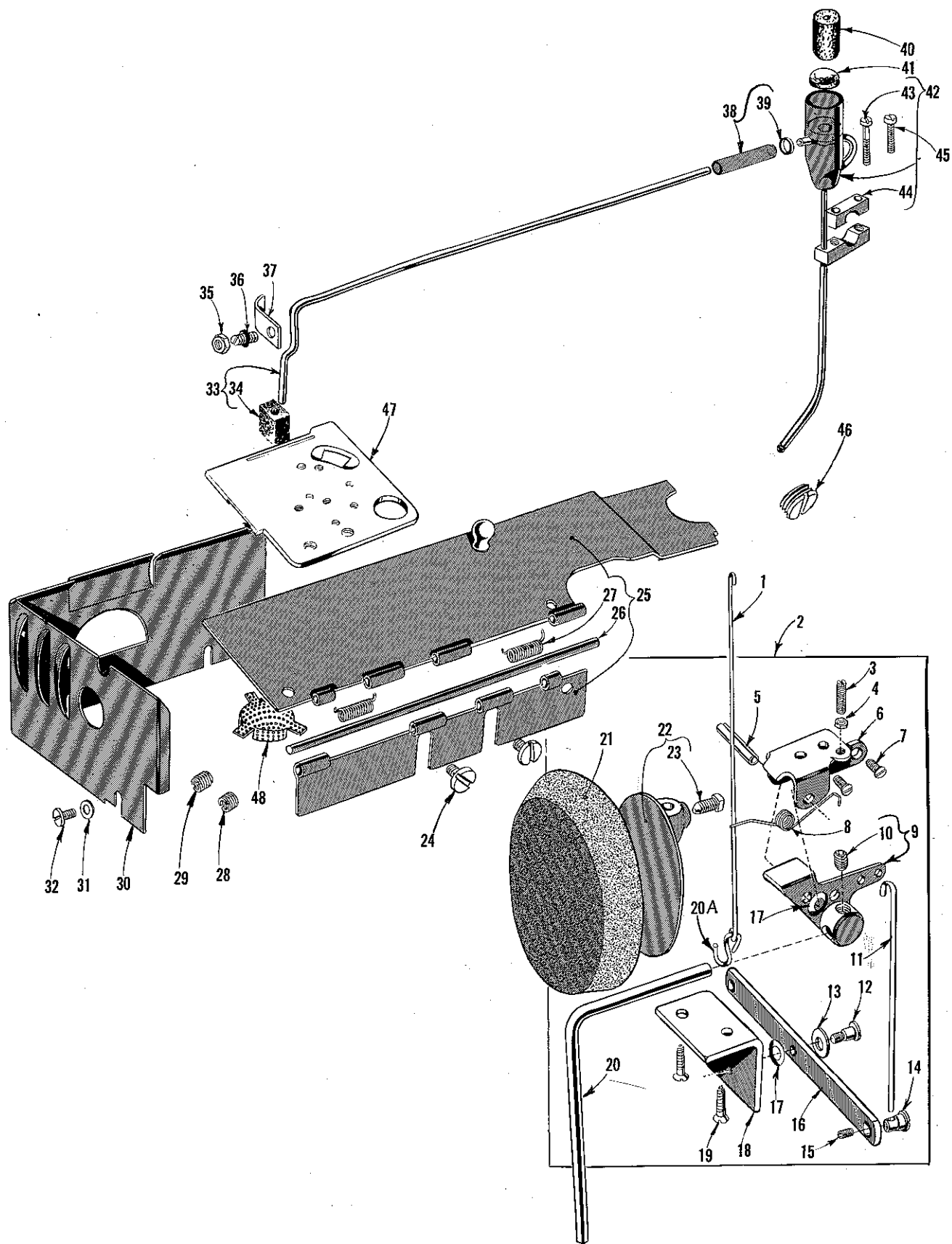

KNEE PRESS ASSEMBLY, OIL SIPHON ASSEMBLY AND
MISCELLANEOUS COVERS

<u>Ref. No.</u>	<u>Part No.</u>	<u>Description</u>	<u>Amt. Req.</u>
1	51493 BC	Lifter Link -----	1
2	21660 H	Knee Press Assembly -----	1
3	92201	Screw -----	1
4	12982	Nut -----	1
5	660-219 G	Roll Pin -----	1
6	21664 F	Mounting Bracket -----	1
7	80	Screw, for attaching -----	2
8	21662 V	Torsion Spring -----	1
9	21662 R	Knee Press Lifter Arm -----	1
10	22650 CE-6	Screw -----	1
11	21662 T	Knee Press Link -----	1
12	22557 A	Screw -----	1
13	43137 E	Washer -----	1
14	21662 S	Knee Press Link Connection -----	1
15	531	Screw -----	1
16	21662 U	Knee Press Lever -----	1
17	39536 AD	Spring Washer -----	2
18	21664 C	Bracket -----	1
19	SC303	Wood Screw, #12 x 1 inch -----	2
20	21663 A	Knee Press Plate Lever -----	1
20A	660-264	"S" Hook -----	1
21	660-168	Knee Press Plate Cushion -----	1
22	21664	Knee Press Plate -----	1
23	69 FD	Screw -----	1
24	25 S	Screw -----	2
25	51282 AJ	Hinged Oil Shield -----	1
26	52978 G	Hinge Pin -----	1
27	51282 AK	Spring -----	2
28	22889 D	Adaptor Plug Screw, left side -----	1
29	22889 C	Adaptor Plug Screw, back -----	2
30	51282 AH	Oil Shield -----	1
31	20	Washer -----	3
32	22848	Screw -----	3
33	51294 M	Oil Siphon Tube -----	1
34	666-214	Felt Lint Filter -----	1
35	7947	Nut -----	1
36	51294 R	Screw -----	1
37	51294 P	Oil Tube Clamp -----	1
38	51294 N	Oil Tube Connection -----	1
39	21212	Locking Ring, for oil siphon connection -----	1
40	666-201	Felt Plug -----	1
41	666-209	Felt Plug -----	1
42	51294 U	Oil Siphon Assembly -----	1
43	22729 B	Screw -----	1
44	51294 K	Clamp, upper -----	1
45	22729 A	Screw -----	1
46	22539 R	Plug Screw, for looper drive oil chamber -----	1
47	51281 AM-227	Cloth Plate Cover -----	1
48	51493 BK	Lint Filter Screen -----	1

BOOST PRODUCTION WITH THESE WORK AIDS FROM UNION SPECIAL

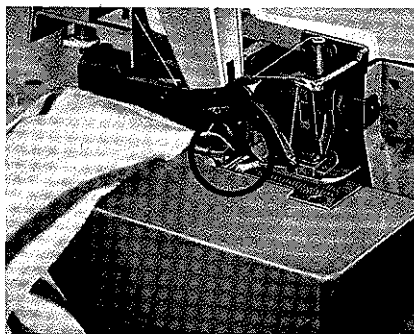

PNEUMATIC CHAIN-CUTTER—for use on conventional Class 39500 and 39600 is a durable scissor-action mechanism that makes a clean positive cut. Style 2899 A-1

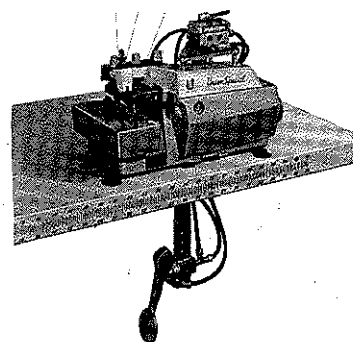

PNEUMATIC FOOT LIFTER—The air-operated foot lifter for use on Class 39500 machines allows the operator to raise the foot simply by knee-touching an actuating switch.

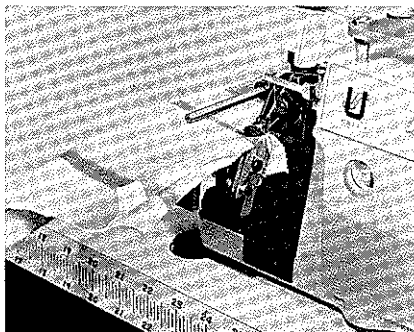

AIR FABRIC UNCURLER—This unit, designed for Class 39500 machines, uses air jets to remove curls from top and bottom plies of flat knit materials as fabric passes through sewing area. Style 2899 B-1

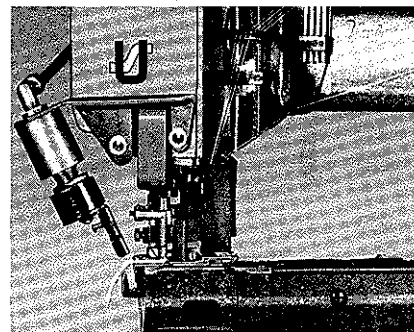

CHAIN CUTTER—The above photo shows the small pneumatic chain cutter that is available for installation as an accessory unit on Class 36200 Flatseamers. Style 2899A-6

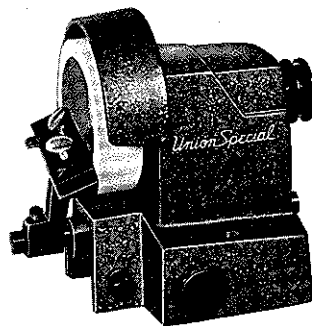
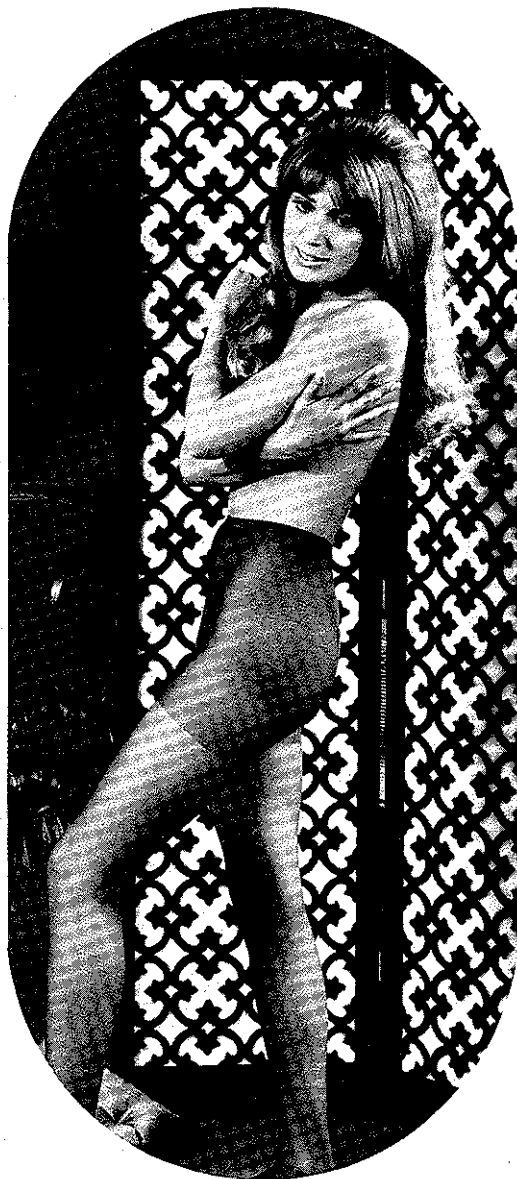

KNIFE GRINDER sharpens straight or angle type knives, is simple and easy to operate, eliminates defective garments caused by dull knives.

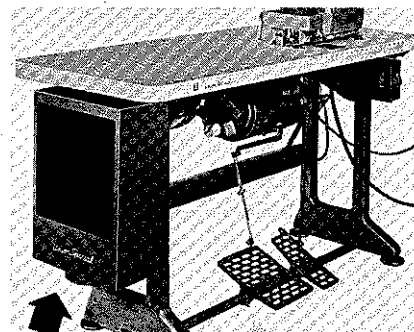

HEAT DISPELLER—Union Special's auxiliary unit (arrow) is an effective means for reducing oil temperature where heavy duty service requires it. Style 2899 E-1

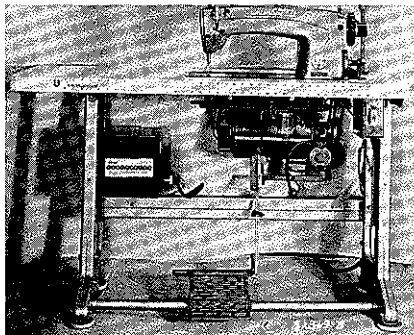

AMCO ELECTRONIC NEEDLE POSITIONERS eliminate the necessity of reaching for the hand-wheel to move the needle up or down . . . this allows the operator to keep both hands on the work, insuring better control, uniform quality and increased production.

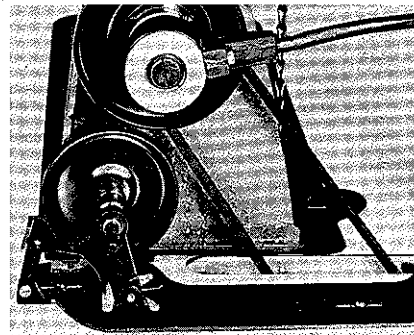

U *Union Special*[®]
FINEST QUALITY CORPORATION

Helpful, authoritative information on the most efficient types of equipment for making virtually any machine sewed article is available from Union Special's Sales Promotion Department. Among the many interesting, illustrated bulletins that are available without obligation are the following:

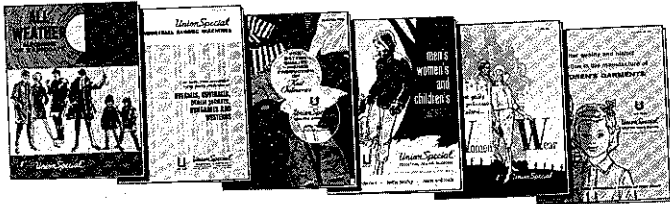

- No. 240, "Men's, Women's, Children's Footwear"
- No. 249, "Rainwear"
- No. 250, "Men's Dress Shirts"
- No. 251, "Service Shirts and Pants"
- No. 252, "Men's Shorts and Pajamas"
- No. 253, "Overalls, Coveralls, and Dungarees"
- No. 254, "Men's Knit Underwear"
- No. 256, "Knit Outerwear"
- No. 259, "Men's Sports Shirts"
- No. 260, "Work Gloves"
- No. 262, "Cotton, Burlap, Jute, and Multiwall Paper Bags"
- No. 263, "Men's Clothing"
- No. 264, "Men's Women's, Children's Jackets"
- No. 265, "Women's Wear"
- No. 266, "Women's Wear And High Fashion"
- No. 267, "Corsets, Girdles, Brassieres"
- No. 268, "Children's Wear"
- No. 269, "Mattresses, Slip Covers, Furniture Upholstery"
- No. 271, "Awnings, Canopies, Tents, Tarps"
- No. 273, "Curtains & Drapes"
- No. 610, "Klipp-it"
- No. 710, "MCS ForMation Unit"
- No. 730, "MCS Automatic Dual Underfront Shirt Hemmer"
- No. 740, "MCS Automatic Rib-Knit Cuff Machine"
- No. 750, "Fusing Presses"
- No. 1100, "Lewis Blindstitch, Chainstitch, Lockstitch, Machines"
- No. 1105, "Button Sewers—Ticket Tackers"
- "Columbia Blindstitch, Saddle Stitch, and Tie Closing Machines"
- No. 1500, "Alteration Department Machines"

 **Union Special**[®]
FINEST QUALITY
CORPORATION

**HERE ARE HELPFUL
BULLETINS and CATALOGS
TO HELP YOU SOLVE
SEWING PROBLEMS**





Union Special[®]
INDUSTRIAL SEWING MACHINES

UNION SPECIAL maintains sales and service facilities throughout the world. These offices will aid you in the selection of the right sewing equipment for your particular operation. Union Special representatives and service men are factory trained and are able to serve your needs promptly and efficiently. Whatever your location, there is a Union Special Representative to serve you. Check with him today.

ATLANTA, GA.

BOSTON, MASS.

CHICAGO, ILL.

DALLAS, TEXAS

LOS ANGELES, CAL.

NEW YORK, N. Y.

PHILADELPHIA, PA.

MONTREAL, CANADA

TORONTO, CANADA

BRUSSELS, BELGIUM

LEICESTER, ENGLAND

LONDON, ENGLAND

PARIS, FRANCE

STUTT GART, GERMANY

Representatives and distributors in all important industrial cities throughout the world.

Union Special

CORPORATION

400 N. FRANKLIN ST., CHICAGO, ILL. 60610